

Installation Instructions

4x4 MiMo Omni-Directional Antenna
DWMM4[G]-6-60
SW3-1026 - v1

Content

EN

Installation Instructions	3-9
Contact Information	11



1. Introduction

The DWMM4[G]-6-60 is a range of omni-directional panel antennas for 4G/5G applications requiring support for 4x4 MiMo with optional GPS/GNSS. Ideal for branch or failover applications the antenna is suitable for external or internal mounting. The antenna is supplied as standard with an offset wall / mast mount bracket and desk mount feet.



Electrical Safety Note

Variants of this product contain an active GPS/GNSS antenna.

Rated voltage: 3-5VDC Rated current: 20mA maximum.

The supply to this device must be provided with overcurrent protection of 1A maximum.

2. Planning the Installation

Choose an installation type and location. The antenna can be wall mounted using the four screw positions or the supplied offset bracket. If mounting to internal walls like drywall, plasterboard or other non-conductive surfaces then the antenna can be directly mounted to the wall. If mounting to concrete walls or walls containing pipes, wiring or foil backed insulation it is advised to use the offset bracket.

The antenna can be mounted to masts of 18-50mm (0.71-1.96") diameter using the supplied offset bracket and mast mount clamps. It can also be desk or panel mounted using the supplied pressed metal feet.

To minimize the effects of surrounding objects, the antenna should be located as far away from other objects and structures as possible. If fitted with GPS/GNSS the antenna should have a clear view of the sky. The antenna is omni-directional, so the antenna does not need to be facing a particular direction. The orientation of the antenna should be vertical with the cable exiting downwards.

3. Safety Notes

- Please seek professional advice from an accredited installer regarding the installation if in any doubt.
- If the antenna will be fitted to an existing mast, please ensure that it will not overload it.
- Ensure that the installation location can be safely accessed with the equipment that you have available.
- If mounting in a position which is accessible care should be taken to ensure that no one comes within 0.3m (1') of the antenna during use.

**CAUTION**

Parts of the antenna are an electrical conductor. Contact with power lines can result in death, or serious injury. Do not install the antenna where there is any possibility of contact with (or high voltage arc-over from) power cables. The antenna and supporting mast must not be close to any power lines during installation, removal or in the event that part of the system should accidentally fall.

**CAUTION**

If the antenna is installed above the roof line or in an exposed location, it is advisable to fit lightning surge arrestors in the coaxial cable feed line. Suitable units should be sourced and installed as per the manufacturer instructions. The installer is responsible for determining if this is a requirement for the antenna installation.

4. Mounting Using the Desk Stand Feet

Fit the supplied folded metal feet to the base of the antenna adjacent to the cable glands using the supplied bolts and washers. Align the screw mount hole on the shortest face of the folded metal foot with the corresponding hole on the back face of the antenna. Tighten securely with the supplied nuts. Do not over-tighten as it may damage the antenna. If a more permanent installation is required on a desk or other surface then the screw holes on the base of the feet can be used to achieved this result.

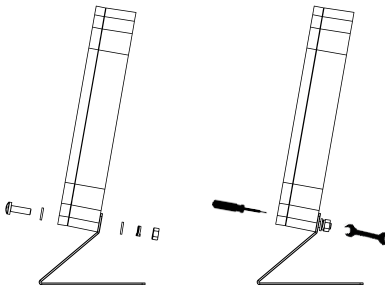
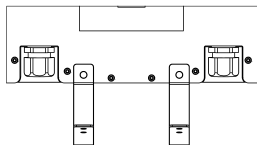
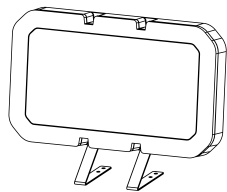

5. Direct Wall Mounting

The antenna can be wall mounted to internal plasterboard, drywalls or other non-conductive panels using two or four of the screw mount positions on the housing. The antenna should be wall mounted with the cables exiting downwards towards the floor. If only using two screw mount positions and not using the supplied offset bracket then the top two screw positions should be used.

Check for adequate clearance behind the wall / panel. Make sure that drilling in the chosen location will not damage any objects, wires or pipes behind the panel. Mark the hole positions, making sure that they are level. The antenna can be used as a template if required. Drill appropriate pilot holes and then increase to the appropriate hole size for the wall anchors / wall plugs that are being used. Fit the wall plugs / anchors securely. Screws up to 5.5mm / No.12 (0.21") can be used to fit the antenna to the wall.

Caution: Do not overtighten the screws as this may damage the antenna.

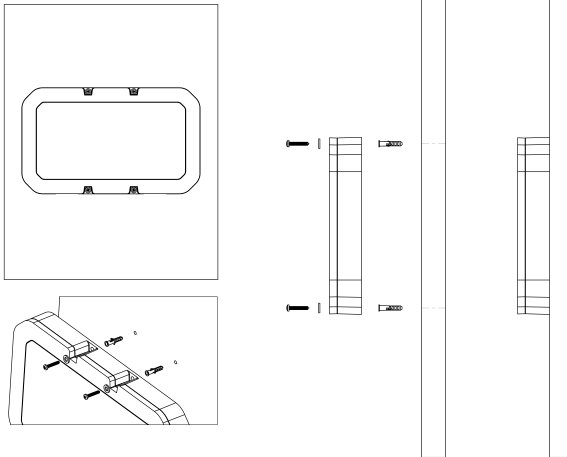

6. Wall Mounting Using Offset Bracket

The antenna should be wall mounted with the cables exiting downwards towards the floor. Sit the antenna onto the shelf on the supplier offset mounting bracket and fix the offset bracket to the antenna using the screws, nuts and washers provided.

Check for adequate clearance behind the wall / panel. Make sure that drilling in the chosen location will not damage any objects, wires or pipes behind the panel. Mark the hole positions, making sure that they are level. The bracket can be used as a template if required. Drill appropriate pilot holes and then increase to the appropriate hole size for the wall anchors / wall plugs that are being used. Fit the wall plugs / anchors securely. Screws up to 5.5mm / No.12 (0.21") can be used to fit the antenna to the wall.

Caution: Do not overtighten the screws as this may damage the antenna.

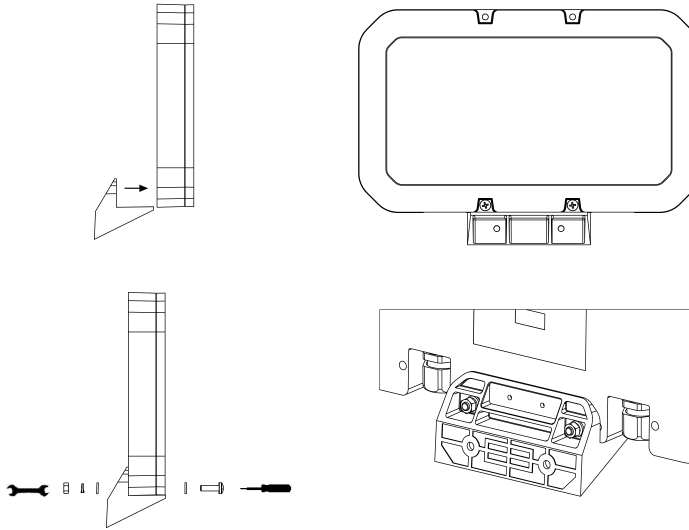

7. Pole/Mast Mounting

The clamp assembly allows fitting to masts of between 20-50mm (0.8" – 2") diameter. Ensure that the selected mounting location can be safely accessed with the equipment that you have available and mount the antenna so that it has at least 1 metre (3.3') of clearance from all obstructions if possible. The antenna should not be mounted directly on to metal walls or backing on to metal masts or poles. If the antenna must be mounted to such a surface it must be mounted at the lip of the roof or the very top of the pole such that the body of the antenna is elevated clear of the metal surface. To maintain GPS/GNSS performance the antenna should not be mounted under roof structures or overhangs.

Sit the antenna onto the shelf on the supplier offset mounting bracket and fix the offset bracket to the antenna using the screws, nuts and washers provided. The supplied mast clamp or U-bolt brackets can then be used to clamp the antenna to the mast.

Caution: Do not overtighten the V bolts as this may damage or distort the mast tube section.

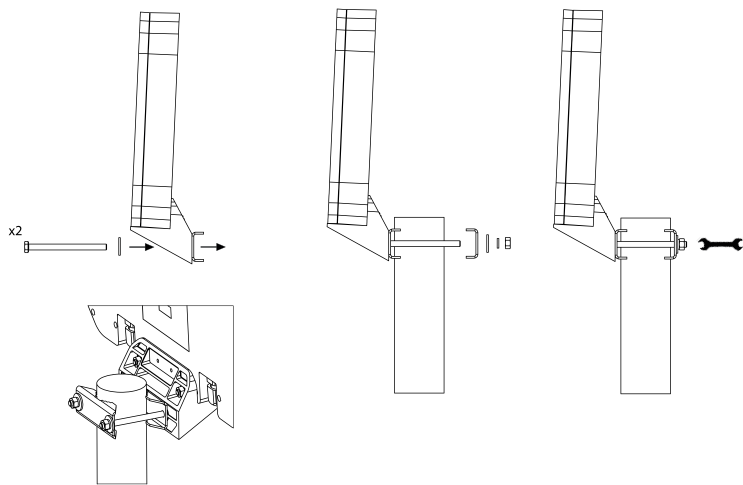

8. Routing and Terminating Coaxial Cable(s)

Plan the coaxial cable route to the wireless device to avoid running adjacent to any existing electrical wiring and ensuring that they will not be subjected to damage.

The 4G/5G antenna feeds are configured with the following polarisations:

Cable 4G/5G A : -45° | Cable 4G/5G B : +45° | Cable 4G/5G C : -45° | Cable 4G/5G D : +45°

Secure the cable run using correct size cable clips, so as not to distort/compress the cable. It is important that the cable is not bent sharply – note that the minimum bend radius for the cable is 25mm (1”) and this should be considered when routing to the cable entry point. Where the antenna is installed externally, it is good practice to create a ‘drip-loop’ at the entry point to avoid water ingress. Any excess cable must not be coiled - it should be laid out in a figure of eight pattern and loosely secured.

SMA (m) connectors are fitted as standard. A 9mm (0.35”) clearance hole is required for the connector – ensure it is not damaged when inserting through the hole.

9. Commission and Test

Check the comms cables:

- Carry out VSWR check, the VSWR should measure <2.5:1.
- Connect the Cellular/LTE cable.

Check GPS cable:

- Check the GPS cable with DC to measure high resistance.
- Connect the GPS cable to the GPS receiver and check for satellite acquisition.

10. Notices



DO NOT

- operate the transmitter when someone is within 20cm (8”) of the antenna.
- operate the equipment in an explosive atmosphere.
- attempt to install the antennas without the proper safe equipment to access the install location.
- install the antenna near overhead power lines
- chew parts or put them in mouth, keep away from unsupervised children.



European Waste Electronic Equipment Directive 2002/96/EC

Waste electrical products should not be disposed of with household waste. All electronic products with the WEEE logo must be collected and sent to approved operators for safe disposal or recycling. Please recycle where facilities exist. Many electrical/electronic equipment retailers facilitate "Distributor Take-Back scheme" for household WEEE. Check with your Local Authority or electronic retailers for designated collection facilities where WEEE can be disposed of for free.



Directive 2011/65/EU (RoHS 2)

RoHS 2 compliance is declared per Directive 2011/65/EU and its subsequent amendments with exemption 6.c applied.

REACH (Registration, Evaluation, Authorisation and Restriction of Chemicals, EC 1907/2006)

This product contains Lead (CAS No. 7439-92-1) which is classified as an SVHC (Substance of Very High Concern) as being toxic to reproduction under Article 57c. of REACH. **Do not chew parts or put them in mouth, keep away from unsupervised children. Dispose of parts as WEEE waste do not send to landfill.**

EU Declaration of Conformity

Object Reference: DWMM4G-6-60-[X]
Object Description: 4x4 MiMo Omni-directional Antenna with GNSS Antenna
Manufacturer: Panorama Antennas Ltd 61 Frogmore, London, SW18 1HF, U.K

This declaration is issued under the sole responsibility of the manufacturer
The object of the declaration described above is in conformity with the relevant Union Harmonization Legislation below:

Directive 2014/53/EU Radio Equipment Directive (RED)

Harmonised Standards and References:

EN 301 489-1 (V2.1.1): "Electromagnetic compatibility and Radio spectrum Matters (ERM); Electro Magnetic Compatibility (EMC) standard for radio equipment and services; Part 1: Common technical requirements".

Referencing EN 61000-4-2:2009 – Electrostatic Discharge Immunity and EN 61000-4-3:2006 +A1:2008 +A2:2010 – Radiated RF Immunity

EN 300 440-1 V1.6.1 (2010-08) – Electromagnetic compatibility and radio spectrum matters (ERM); short range devices; radio equipment to be used in the 1GHz to 40GHz frequency range; Part 1: Technical characteristics and Test methods in accordance with EN 300 440-2 V1.4.1 (2010-8) - Electromagnetic compatibility and radio spectrum matters (ERM); short range devices; radio equipment to be used in the 1GHz to 40GHz frequency range

Low Voltage Directive: Directive 2014/35/EU (Electrical Equipment designed for use within certain voltage limits) of 26th February 2014.

EN62368-1: 2014 Audio/video, information and communication technology equipment. Safety requirements

Waiver: This document represents information compiled to the best of our present knowledge. It is not intended to as a representation or warranty of fitness of the products described for any particular purpose.

This document details guidelines for general information purposes only. Always seek specialist advice when planning installations and ensure that antennas are always installed by a properly qualified installer in compliance with local laws and regulations.

Contact Information

Panorama Antennas Ltd

Head Office - United Kingdom
61 Frogmore, Wandsworth, London, SW18 1HF
sales@panorama-antennas.com
+44 (0)20 8877 4444

Panorama Antennas Inc

USA
1551 Heritage Parkway, Suite 101, Mansfield, TX, 76063
sales.nam@panorama-antennas.com
+1 817-539-1888

Panorama Antennas Pty Ltd

Australia
Unit 1, 5 Jaggs Way, Kardinya, WA 6163
sales.apac@panorama-antennas.com
+61 406 812 364

Panorama Antennas SAS

France
16 Allée des Acacias, 33700 Mérignac
fr.sales@panorama-antennas.com
+33 554 070 436

Panorama Antennas Pte Ltd

Singapore
Space@ Tampines, 18 Tampines Industrial Crescent, 528605
sales.sea@panorama-antennas.com
+65 9155 4194

Panorama Antennas Ltd

Germany
de.sales@panorama-antennas.com
+49 2303 902 88 00



